

# Weighfeeders

**SITRANS WW300**

Operating Instructions · 03/2010

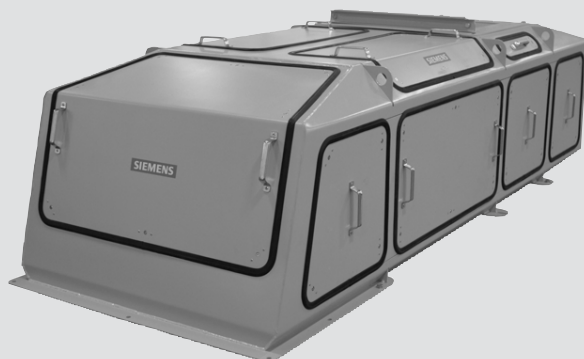

**SITRANS**

**SIEMENS**

**Safety Guidelines:** Warning notices must be observed to ensure personal safety as well as that of others, and to protect the product and the connected equipment. These warning notices are accompanied by a clarification of the level of caution to be observed.

**Qualified Personnel:** This device/system may only be set up and operated in conjunction with this manual. Qualified personnel are only authorized to install and operate this equipment in accordance with established safety practices and standards.

**Unit Repair and Excluded Liability:**

- The user is responsible for all changes and repairs made to the device by the user or the user's agent.
- All new components are to be provided by Siemens Milltronics Process Instruments Inc.
- Restrict repair to faulty components only.
- Do not reuse faulty components.

**Warning:** Cardboard shipping package provides limited humidity and moisture protection. This product can only function properly and safely if it is correctly transported, stored, installed, set up, operated, and maintained.

**This product is intended for use in industrial areas. Operation of this equipment in a residential area may cause interference to several frequency based communications.**

**Note:** Always use product in accordance with specifications.

**Copyright Siemens Milltronics Process Instruments Inc. 2010. All Rights Reserved**

This document is available in bound version and in electronic version. We encourage users to purchase authorized bound manuals, or to view electronic versions as designed and authored by Siemens Milltronics Process Instruments Inc. Siemens Milltronics Process Instruments Inc. will not be responsible for the contents of partial or whole reproductions of either bound or electronic versions.

**Disclaimer of Liability**

While we have verified the contents of this manual for agreement with the instrumentation described, variations remain possible. Thus we cannot guarantee full agreement. The contents of this manual are regularly reviewed and corrections are included in subsequent editions. Please check the website shown below for the latest manual revisions. We welcome all suggestions for improvement.

Technical data subject to change.

MILLTRONICS® is a registered trademark of Siemens Milltronics Process Instruments Inc.

**Contact SMPI Technical Publications at the following address:**

Technical Publications  
Siemens Milltronics Process Instruments Inc.  
1954 Technology Drive, P.O. Box 4225  
Peterborough, Ontario, Canada, K9J 7B1  
Email: [techpubs.smpi@siemens.com](mailto:techpubs.smpi@siemens.com)

**European Authorized Representative**

Siemens AG  
Industry Sector  
76181 Karlsruhe  
Deutschland

- For a selection of Siemens Milltronics level measurement manuals, go to: **[www.siemens.com/level](http://www.siemens.com/level)**. Choose **Instructions and Manuals** under the More Info list.
- For a selection of Siemens Milltronics weighing manuals, go to: **[www.siemens.com/weighing](http://www.siemens.com/weighing)**. Choose **Support**, and then **Manuals / Operating Instructions**.

# Table of Contents

---

<b>SITRANS WW300 .....</b>	<b>1</b>
Safety notes .....	1
The manual .....	1
Technical Support .....	2
<b>Safety .....</b>	<b>3</b>
Safety and general precautions .....	3
<b>Specifications .....</b>	<b>4</b>
<b>Operation .....</b>	<b>6</b>
Weighfeeders .....	6
<b>Mechanical installation .....</b>	<b>7</b>
Installation .....	7
<b>Calibration .....</b>	<b>9</b>
Test Load .....	9
Zero .....	9
Span .....	9
<b>Wiring .....</b>	<b>10</b>
<b>Start Up .....</b>	<b>11</b>
Shear Gate .....	11
Skirtboards .....	11
Changing the Conveyor Belt .....	11
Belt Tension .....	12
Belt Tracking ( <i>for self steering units the belt will track itself</i> ) .....	12
Telescoper Adjustment .....	13
Panel Removal .....	14
Load Cell Replacement .....	14
Removing Old Dual Beam Load Cell .....	14
Installing New Dual Beam Load Cell .....	15
Removing Old Triple Beam Load Cell .....	15
Installing New Triple Beam Load Cell .....	16
Calibration .....	16
Weighing Idler Alignment .....	16
Quick Start Up Overview .....	17
<b>Troubleshooting .....</b>	<b>18</b>
Mechanical Troubleshooting .....	18
Zero Drift, Non-Repeatability, or Non-Linearity .....	18
<b>Maintenance .....</b>	<b>19</b>
Preventative Maintenance .....	19

Recommended Preventative Maintenance Schedule .....	19
General Maintenance .....	19
Lubrication .....	20
Weighfeeder Storage Recommendations .....	20

**Dimensions .....** **21**

Open Unit .....	21
Enclosed Unit .....	22

# SITRANS WW300

---

SITRANS WW300 is a medium-to-high capacity weighfeeder for macro ingredient additives. It is designed for industrial applications such as mining, cement, chemical processing, pulp and paper, and other heavy-duty industries.

SITRANS WW300 comes with weigh bridge, speed sensor, and test weights. An integrator is required to complete the system.

## Safety notes

Special attention must be paid to warnings and notes highlighted from the rest of the text by grey boxes.



**WARNING** means that failure to observe the necessary precautions can result in death, serious injury, and/or considerable material damage.

**Note:** means important information about the product or that part of the operating manual.

## The manual

### Notes:

- SITRANS WW300 is to be used only in the manner outlined in this instruction manual.
- This product is intended for use in industrial areas. Operation of this equipment in a residential area may cause interference to several frequency based communications.

This instruction manual covers the operation, installation, and maintenance of SITRANS WW300. Specific information for your Weighfeeder model is also included such as: motor, reducer, testing documents, customer application data, spare parts.

Please refer to this manual for proper installation and operation of SITRANS WW300. Adhering to the installation and operating procedures will ensure quick, trouble-free installation and allow for maximum accuracy and reliability of your weighfeeder.

If you have any questions, comments, or suggestions about the manual contents, please email us at [techpubs.smpi@siemens.com](mailto:techpubs.smpi@siemens.com).

For the complete library of Siemens manuals, go to [www.siemens.com/weighing](http://www.siemens.com/weighing).

# Technical Support

Support is available 24 hours a day.

To find your local Siemens Automation Office address, phone number and fax number go to:

[www.siemens.com/automation/partner](http://www.siemens.com/automation/partner)

- Click on the tab Contacts by Product then find your product group (+Process Automation > +Process Instrumentation > +Level Measuring Instruments).
- Select the team Technical Support. Click on Next.
- Click on the appropriate continent, then select the country followed by the city. Click on Next.

For on-line technical support go to:

[www.siemens.com/automation/support-request](http://www.siemens.com/automation/support-request)

- Enter the device name (SITRANS WW300) or order number, then click on Search, and select the appropriate product type. Click on Next.
- You will be prompted to enter a keyword describing your issue. Then either browse the relevant documentation, or click on Next to email a detailed description of your issue to Siemens Technical Support staff.

<b>Siemens A&amp;D Technical Support Center:</b>	phone	+49 180 50 50 222
	fax	+49 180 50 50 223

# Safety

---

## Safety and general precautions



### WARNINGS:

- Always follow safe practices when working on or around SITRANS WW300, especially in wet environments and when adjacent to conductive steel mounting framework.
- ALWAYS STOP the belt, lock-out, and/or place a "Do Not Energize" tag on the main disconnect before working on or around the weighfeeder.

**Note:** A weighfeeder can be dangerous. Pinch points exist along the conveyor belt line.

Secure the weighfeeder when:

- replacing the belt
- working on or around the load cell(s)
- working on or around the speed sensor
- working on or around the drive components

# Specifications

---

## Accuracy

- $\pm 0.5\%$ <sup>1</sup>

## Operating temperature

- -10 to +40 °C (+14 to +104 °F)

## Materials

- mild steel with stainless steel [304 (1.4301) or 316 (1.4401)], abrasive resistant contact parts optional

## Load cells

- two corrosion resistant platform type with mechanical overload protection
- non-linearity:  $\pm 0.03\%$
- non-repeatability:  $\pm 0.02\%$

## Speed sensor

- industrial duty, digital optical encoder, tail shaft mounted

## Framework

- cantilevered painted mild steel structural frame for quick and easy belt replacement

## Pulleys

- 200 to 500 mm (8 to 20"), crowned with 6 mm (¼") rubber lagging on drive pulley for maximum traction, 200 to 500 mm (8 to 20") crowned tail.

## Idlers

- heavy-duty 100 mm (4") CEMA C with precision ground ball bearings and triple labyrinth seals for longer life, CEMA D, E, impact where required

---

<sup>1</sup>. Accuracy subject to: On factory approved installations the weigh feeder system's totalized weight will be within the specified accuracy when compared to a known weighed material test sample. The test rate must be within the specified range of the design capacity and held constant for the duration of the test. The minimum material test sample must be equivalent to a sample obtained at the test flow rate for three revolutions of the belt or at least ten minutes running time, whichever is greater.

## Belting

- black rubber, 150-440 PIW 2-4 ply vulcanised endless
- 'B' section (standard)
- up to 130 mm (5") corrugated sidewalls (optional)

## Belt tension

- screw type, telescoper module with 150 mm (6") min. travel
- self steering tensioner (optional)

## Belt cleaning

- gravity tensioned UHMW blade at head pulley
- return plow at tail pulley

## Drive

- 0.19 kW (0.25 HP) min., TEFC, or TENV 208/230/380/460/575 V AC, three phase or 90/180 V DC permanent magnet - both with shaft mounted gear reducer
- larger/other motor sizes and voltages available

## Shipping weight

- 410 kg (900 lbs) minimum

## Approvals

- for use in hazardous rated areas, consult with factory

# Operation

---

## Weighfeeders

Weighfeeders weigh bulk material while it is conveyed. An accurate rate of flow and totalized weight measurement is received without interrupting the flow of material in process. A weighfeeder can also control the rate of flow of the conveyed product.

In-motion weighing requires accurate transmission of the product load to strain gauge load cells. The resulting voltage signal corresponding to weight is transmitted to the integrator and becomes one of the two inputs required for integration.

Unlike static weighing, in-motion weighing integration requires a second input: a pulse signal proportional to the speed of the conveyor belt. Each belt speed sensor pulse represents a fixed distance of travel.

Since the force measured by the load cell is represented as weight per unit length, it can be multiplied by the distance of belt travel (one speed sensor pulse) to provide product weight for that segment of the belt (lbs/ft x ft = lbs, or kg/m x m = kg).

**Enclosed**

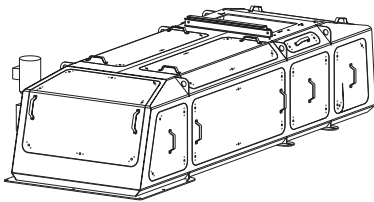

**Open**

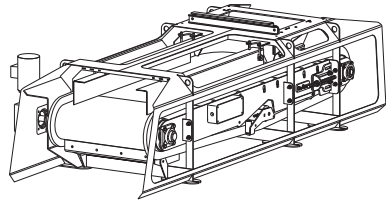

# Mechanical installation

Perform a thorough and systematic inspection of containers immediately upon receipt of your Siemens weighfeeder. The containers are packed to separate each item and provide protection during shipping.

**Note:** Do not remove equipment from shipping crates or boxes until you check for possible shipping damage. Contact the carrier immediately if damage is noted.

Your weighfeeder has been designed, assembled, and factory tested for your specific application.

## Notes:

- Refer to the mechanical drawings sent with this manual prior to commencing with installation.
- Do **NOT** remove the tagged load cell shipping bolt(s) until the installation is complete to prevent load cell damage.
- Do **NOT** weld on or near the weighfeeder while the load cell is connected to the electronic integrator. Damage to the integrator may result if the load cell is not disconnected from the integrator.
- Follow a scheduled, preventative maintenance program to ensure optimum performance and long equipment life.

## Installation

**Note:** Only qualified personnel are authorized to install and operate this equipment. Installation shall be in accordance with local regulations, standards and established safety practices. Read and understand the instructions before installing, operating or maintaining the equipment.

1. Align the in-feed section of the weighfeeder with the discharge of the feed device. Prevent twisting or misalignment that could induce stress on the weighing section.
2. Securely fasten the unit to a rigid, level structure. Use a level for verification and shim as necessary. Prevent any twisting of the frame that may affect weighfeeder performance.
3. Construct the necessary support framework to provide a sturdy, rigid base. Vibration isolators are recommended if the location is subject to moderate or heavy vibration.
4. Check the gear reducer oil level. See the gear reducer manual for further details on maintenance.
5. Flexible in-feed connections are **REQUIRED** for all applications. Flexible discharge connections are also recommended. The unit is shipped with a gear reducer breather; install the breather in the appropriate fill hole per the included reducer manual.

**Note:** Inlet and discharge will not support load.

6. Connect the proper electric supply to the motor and/or motor controller, following the interwiring diagram supplied with this manual. The AC or DC motor controller (if present) must be grounded to minimize noise to the electronic integrator. Refer to the applicable wiring diagram to make all electrical connections between the electronic integrator and the weighfeeder.
7. Remove only the TAGGED shipping bolt or bracket that is attached to the dual beam load cell types only. This bolt supports the weighbridge during transport and installation.

**Note: DO NOT** loosen or tighten the overload bolt (on dual beam loadcells) — it has been factory set to minimize the possibility of load cell damage resulting from incidental overload.

8. Before starting the machine, make a final check to see that the conveyor belt is free of all tools and foreign objects.

# Calibration

---

After SITRANS WW300 has been properly installed, calibration of the weighing system must be done in conjunction with the integrator. Refer to the integrator instruction manual for programming and calibration. The calibration is initially done using the supplied test load. Material tests are recommended to achieve maximum accuracy.

## Test Load

The test load value for your SITRANS WW300 is given on the accompanying factory test sheet, in kilograms per meter or pounds per foot.

## Zero

Perform the zero calibration as described in the Calibration section of the integrator manual.

## Span

The test load used in the calibration procedure is a set of factory sized and supplied test weights (2 or more).

Perform the span calibration as described in the Calibration section of the integrator instruction manual.

After the span calibration has been completed, remove the test load and store it.

# Wiring

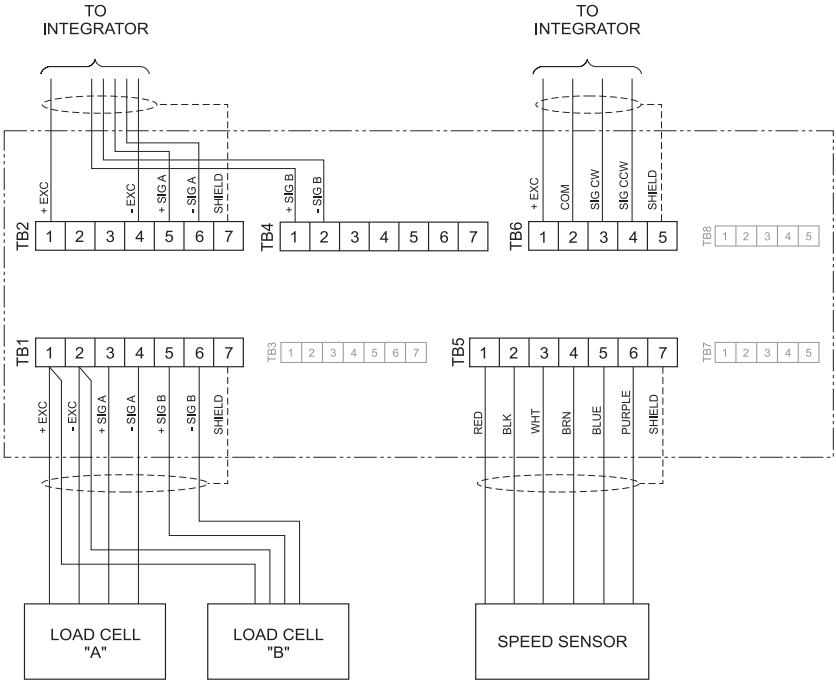

# Start Up

---

Your weighfeeder has been factory run-in for a minimum of four hours; it should require little adjustment. However, periodic inspections of the belt tracking are recommended.

Start the belt and observe rotation.

**!** **WARNING: Turn off and lock out all power sources before correcting rotation. On DC motors, reverse the armature wires. On AC motors, reverse 2 of the 3 motor wires.**

Start the belt again and observe the machine as it is running. If the belt is not tracking correctly, see *Belt Tracking* on page 12.

## Shear Gate

The shear gate on the inlet of the weighfeeder needs to be set to allow the maximum feedrate capacity for the application, height is provided in the outline drawings included. Consult your Siemens representative if feed rate changes are required.

## Skirtboards

The skirtboards have been factory set. Note that near the inlet, the skirtboards are very close to the belt. However, the distance between the skirtboards is greater at the discharge end: the skirtboards are 1/8 to 3/16" off the belt. This tapering improves material flow and will help the product move down the belt without "bottlenecking."

Adjustments of the skirtboards should not be necessary but if they are required, set the skirtboards at the heights described above.

## Changing the Conveyor Belt

**!** **WARNING: ALWAYS STOP the belt, lock-out, and/or place a "Do Not Energize" tag on the main disconnect before working on or around the weighfeeder.**

1. Open and remove the access and non-access side covers (omit this step on open construction models).
2. Mark the position of the telescopers for reference. This will be handy when you re-install the belt. Loosen the telescopers to remove tension from the belt.

3. At the discharge end of the conveyor, find the belt scraper weight tensioner. Remove the weight(s) from the belt scraper arm and let the belt scraper swing down away from the belt.

**Note:** Skirtboard removal or adjustment is not normally necessary to perform belt removal or installation, nor is it recommended. On corrugated belts the skirtboards are designed to hang on a pivot, out of the way without full removal.

4. Remove support posts on the access site.
5. From the access side of the feeder at the discharge end, grab the edge of the belt on the top and bottom. Gently pull the belt over the side rail, making sure that the leading edge of the belt does not catch on the side rail.
6. Now repeat Steps 4 and 5 on the inlet end of the feeder. Again, be careful not to cut or scrape the belt on the side rail.
7. When both ends have been pulled to the outside of the side rail, you may grab the belt in the middle and slowly remove the belt. As the belt is removed, mark the direction the belt was rotating. This mark will allow you to re-install the belt in the same direction. Take care when storing the belt to prevent kinks or other damage.
8. With the belt removed, inspect the feeder for material build up, lodged particles, and signs of wear, paying close attention to the weigh section. Take care when cleaning the weigh section area, as 25 lbs. (or less) pressure placed on the weighbridge could cause load cell damage.
9. Reverse steps 1-7 to re-install the same belt.

**Note:** On a new replacement belt, there may be an arrow printed on the underside of the belt. This arrow indicates what direction the belt should rotate when it is installed. If there is no arrow, rotation of the belt may be in either direction. Whenever a new belt is installed, perform the belt tracking procedure (see *Belt Tracking* on page 12).

## Belt Tension

The ideal belt tension for any weighfeeder is just enough tension to prevent the belt from slipping on the drive pulley. The tension minimizes the effect of the belt on weighing accuracy. Often, the cause of an inaccurate weighfeeder is excessive belt tension.

Specific belt tension cannot be given because the weighfeeder could be mounted in various applications. As a general guideline, the bottom of the belt should droop 1-2" over the length of the weighfeeder. This is only an approximate specification, as your application may require more or less tension due to varying belt loading and other operating characteristics.

## Belt Tracking *(for self steering units the belt will track itself)*

1. Before attempting to track the belt, be sure:
  - belt scraper is in place
  - belt tension is near guidelines suggested on page 12
  - feeder is level and true

- frame is not warped or twisted
  - head and tail pulley are parallel to each other
  - plow is contacting underside
2. Turn on the feeder and observe its tracking line on the head and tail pulleys. If the belt is drifting toward one side of the feeder, then adjust the telescoper on either side of the machine (see below).
  3. Do not adjust belt tracking rollers, they have been factory set.

## Telescoper Adjustment

1. Determine which side of the weighfeeder you want to adjust. Compressing the telescoper on one side will cause the belt to drift toward that side of the weighfeeder. Conversely, extending the telescoper will cause the belt to drift away from that side of the weighfeeder.
2. Loosen the jam nut.
3. Turn the adjusting screw in the desired direction. Often, only a small adjustment (1 turn or less) is required.
4. Observe the results of the adjustment and then readjust, if necessary.

**Note:** As you extend or compress the telescoper, you may be changing the belt tension. If belt tension has increased (or decreased) considerably while attempting to track the belt, then compress (or extend) both telescopers and complete the belt tracking process again. To avoid this problem, extend one telescoper while compressing the other to obtain proper belt tracking.

5. Re-tighten the jam nut located on the telescoper to maintain the new telescoper position after completing the tracking procedure.
6. If you are having problems tracking the belt, consult your Siemens representative. Common causes of belt tracking problems are: uneven or improperly distributed product loading, twisted frame, or product build-up on head or tail pulleys.

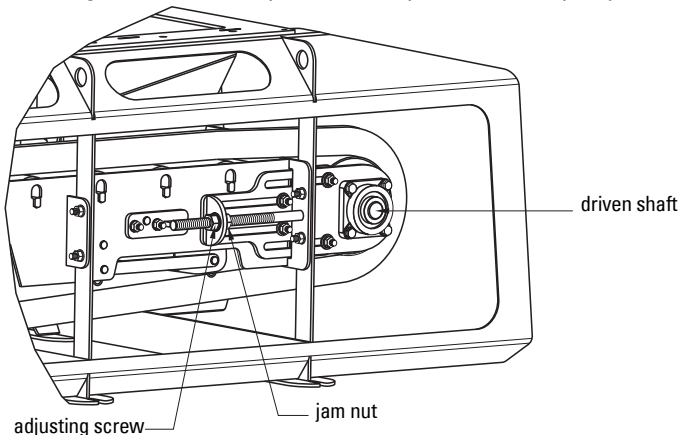

# Panel Removal

Using a hex key, turn the panel mounts 90 degrees per the label attached to the panel around the mount to release, inspect the gasketing to ensure it creates a positive seal against the body of the enclosure.

## Load Cell Replacement

**!** **WARNING: ALWAYS STOP the belt, lock-out, and/or place a "Do Not Energize" tag on the main disconnect before working on or around the weighfeeder.**

If a load cell on SITRANS WW300 has been damaged, is not functioning, or if you are changing the capacity, you will need to replace one or all load cells.

**Note:** Please read and understand all of the instructions before proceeding with the replacement. Contact your Siemens representative for assistance.

## Removing Old Dual Beam Load Cell

1. Confirm the new replacement load cell is correct and functional. Using a digital volt meter or ohm meter, verify that the resistance of the new load cell matches the resistance printed on the specification sheet that comes with the load cell. If the resistances do not match, the load cell may be damaged. Consult your Siemens representative.
2. Disconnect the load cell being replaced from the junction box. Verify that the load cell is connected according to the interwiring diagram supplied with this manual. Disconnect the load cell from the load cell junction box. Free the load cell cable from the feeder so it is hanging free from the load cell.
3. Install the shipping screw (tagged) through the bottom load cell mount and into the load cell. Tighten the shipping screw until the load cell bottoms out on the overload screw.

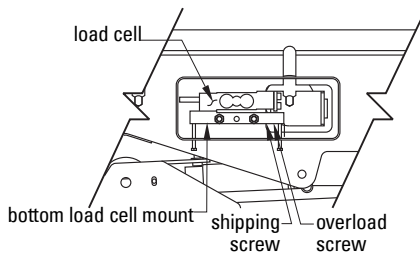

4. Support the scale idler and remove the two top load cell mount bolts. Be careful not to move the idler as it is still attached to the load cell on the other side of the weighfeeder.
5. Remove the two bottom load cell mount bolts. The load cell is now held in place only by the shipping bolt.

6. Support the scale idler with a block of wood or have an assistant hold it. Remove the shipping screw and slide the load cell off the feeder.

## Installing New Dual Beam Load Cell

1. Slide the new load cell into position and carefully screw in the load cell shipping screw. Do not overtighten the screw.
2. Install the two bottom load cell mount bolts. Tighten them by hand. Now re-tighten the shipping bolt so the load cell is resting against the overload stop.
3. Install the two top load cell mount bolts. Tighten them by hand.
4. Start with the bottom load cell mounting bolts and tighten them. Now tighten the two top load cell mounting bolts to the value provided with the loadcell replacement.
5. Remove the shipping screw.
6. Route the load cell cable to the junction box and connect the load cell according to the supplied interwiring diagram. Repeat for other load cells if necessary.
7. Perform a load cell balancing procedure as described in the integrator instruction manual.

## Removing Old Triple Beam Load Cell

1. Confirm the new replacement load cell is correct and functional. Using a digital volt meter or ohm meter, verify that the resistance of the new load cell matches the resistance printed on the specification sheet that comes with the load cell. If the resistances do not match, the load cell may be damaged. Consult your Siemens representative.
2. Disconnect the load cell being replaced from the junction box. Verify that the load cell is connected according to the interwiring diagram supplied with this manual. Free the load cell cable from the feeder so it is hanging free from the load cell.
3. Support the scale idler and remove the two front load cell mount bolts. Be careful not to move the idler as it is still attached to the load cell on the other side of the weighfeeder.
4. Remove the two bottom load cell mount bolts.
5. Support the scale deck with a block of wood or have an assistant hold it and slide the load cell off the feeder.

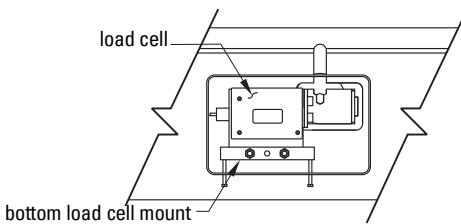

# Installing New Triple Beam Load Cell

1. Slide the new load cell into position.
2. Install the two front load cell mount bolts. Tighten them by hand.
3. Start with the bottom load cell mounting bolts and tighten them to 200 in-lb torque. Now tighten the two front load cell mounting bolts to 200 in-lb torque.
4. Route the load cell cable to the junction box and connect the load cell according to the supplied interwiring diagram. Repeat for other load cells if necessary.
5. Perform a load cell balancing procedure as described in the integrator instruction manual.

## Calibration

1. Power up the integrator and using the appropriate integrator menu, verify that the new load cell(s) are operating correctly.
2. Zero calibrate the unit using the integrator manual for reference. Record zero calibration procedure results.
3. Span calibrate the unit using the integrator manual for reference. Record span calibration procedure results.
4. Run another zero calibration and record the results. Verify that the repeated zero shows the same value as recorded in step 2.
5. Confirm calibration with material test as described in the integrator manual, if possible, before placing the feeder back in operation.

## Weighing Idler Alignment

Precise idler alignment is very important to achieve maximum accuracy of the weighing system. Misaligned idlers will result in unwanted forces being applied on each idler in the weighing area, causing calibration and measurement errors. Verify that the weighing idler is aligned properly. Use a spirit level to level the load cells.

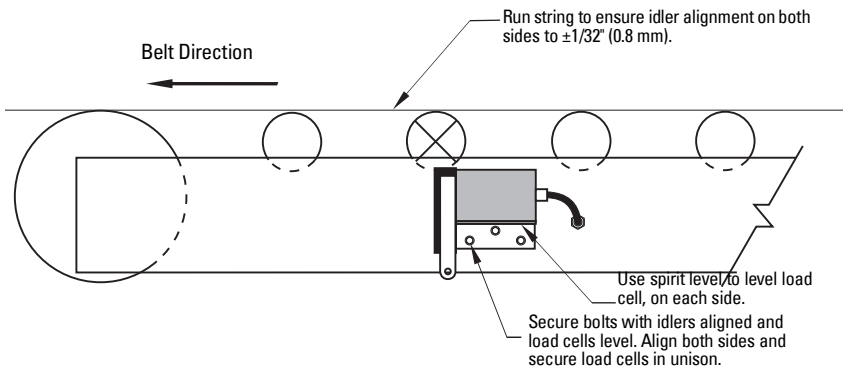

# Quick Start Up Overview

1. Verify that the weighfeeder is installed properly as described in the “Mechanical installation” on page 7. Verify that the belt is tracking and the shear gate (if used) is properly set.
2. Verify that the weighfeeder, integrator/controller, and variable speed drive (AC or DC, if present) are all properly wired.
3. Verify that the data on the design data sheet included with this manual is correct and modify if required.
4. Refer to the supplied integrator/controller information for calibration and configuration information.

# Troubleshooting

---

## Mechanical Troubleshooting

Review mechanical installation procedures and perform a thorough visual inspection to be sure the operating error is caused by a mechanical problem. Then review and check the common problems listed below.

**Note:** Contact your Siemens representative for assistance determining the cause of the problem. Be sure to have the Model Number and Serial Number of your system and all of the calibration and setup parameters available before calling.

## Zero Drift, Non-Repeatability, or Non-Linearity

Check for the following conditions:

- weigh idler alignment. Verify weigh idler alignment is accurate (should be  $\pm 1/32$ " (0.8 mm) aligned with slider bars approach and retreat). Improper alignment is the most common mechanical problem affecting scale accuracy. Contact your Siemens representative for further assistance.
- material buildup on weigh section, pulleys, or between the idlers and feeder frame.
- belt mis-tracking.
- tight belt.
- loose load cell bolts.
- speed sensor, pulley, or idler slippage.
- load cell shipping bolt (tagged) never removed.
- head or tail pulley relative to idler alignment. The head and tail pulleys should be at least 1/8" lower than the approach and retreat idlers.

# Maintenance

**!** **WARNING: ALWAYS STOP the belt, lock-out, and/or place a "Do Not Energize" tag on the main disconnect before working on or around the weighfeeder.**

## Preventative Maintenance

The maintenance schedule below is recommended to maintain top performance and accuracy of the system. Weighfeeders mounted in severe weather or dusty conditions may require a more rigorous maintenance schedule.

Make sure the weigh idler is aligned with the approach and retreat sections for accurate weighing. Periodic measurement to verify alignment is recommended.

## Recommended Preventative Maintenance Schedule

Item	Required Maintenance	Frequency	Comments
Weigh Section	Blow or brush off any material building up	Weekly	More frequently in dirty environments
Belt Tracking	Visually inspect to assure the conveyor belt remains trained	Daily	-----
Calibration Verify belt zero	Verify belt zero	Daily or at least once a week	See Calibration section of Integrator Manual
Calibration span check	Use Calibration weights	Monthly	See Calibration section of Integrator Manual
Bearings	Inspect and lubricate as required	Every 10,000 hours	Use #3 NLGI grade lithium base grease
Electric motor (DC)	Check brushes	Every 10,000 hours	Inspect and replace as necessary
Electric motor (AC)	None	None	Bearings are sealed and permanently lubricated
Gear reducer	Check oil level/Replace oil	Monthly/ Every 2,500 hours	Refer to manufacturer maintenance manual/See note on next page

## General Maintenance

The equipment should be cleaned periodically and any excess accumulation of product should be removed to minimize potential damage to the mechanical components and scale accuracy.

Abrasions, cuts, or ragged edges on the belt will create performance problems. Replace the belt if it becomes ragged or torn.

# Lubrication

All head and tail pulley bearings are greased at the factory. These bearings should be field greased periodically. Lubrication frequency may vary; dry, dusty applications may warrant weekly greasing, while less harsh applications may need greasing only once or twice a year. Do not exceed 10,000 hours of operation between re-greasing.

The tensioner and belt rollers use a sealed bearing, so greasing is not necessary.

If there is a gear reducer supplied with your weighfeeder, it has an initial break-in period. After the first 250 hours of operation, the gear box(es) should be drained and refilled to the proper level(s). Subsequent oil changes should be done every 2500 hours. See the gear reducer manual provided for further details.

If there is a gear motor (motor and reducer all in one housing) supplied with your unit, it is permanently lubricated. No lubrication is necessary.

## Weighfeeder Storage Recommendations

If a weighfeeder will be stored for a period of three months or more, follow the guidelines below:

### Load cell care

The load cell shipping bolts should be installed whenever the feeder is moved as an extra safety measure during the storage period. Do not forget to remove the shipping bolts upon re-installation.

### Gear reducer/gear motor

Uncouple the gear reducer from the feeder drive shaft and the motor and grease all shaft surfaces liberally with an appropriate lubricant to help with reassembly.

In addition, fill the gear reducer with an appropriate gear oil to prevent oxidation. When the equipment is re-installed, completely drain this gear oil and then refill the reducer to the appropriate level.

### Electrical

To prevent oxidation, place a desiccant or moisture removal material in all electrical junction boxes and component cabinets. This includes the load cell junction box, the integrator cabinet, and the motor speed controller enclosure (if present).

### Lubrication

Grease all greasable points.

### Belt care

Reduce belt tension to a minimum to prevent belt damage and re-adjust belt tension at re-installation.

**Note:** Do NOT store the weighfeeder in direct sunlight, as this will cause premature breakdown of the belt.

# Dimensions

## Open Unit

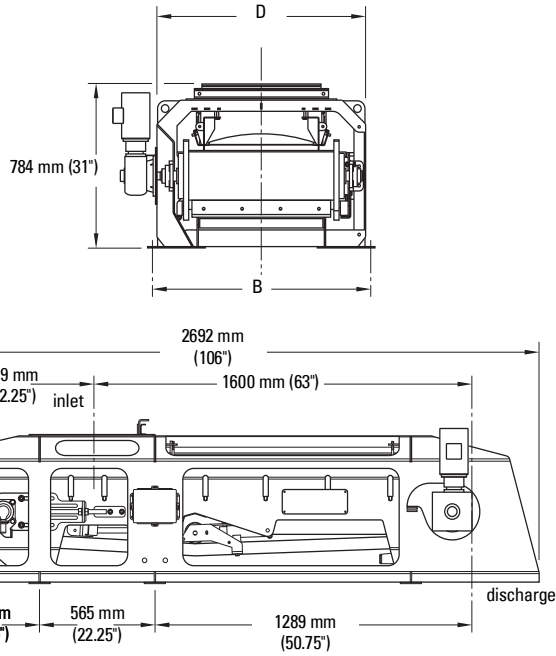

Belt Width	B	D
457 mm (18")	768 mm (30.25")	718 mm (28.25")
610 mm (24")	921 mm (36.25")	870 mm (34.25")
762 mm (30")	1073 mm (42.25")	1022 mm (40.25")
914 mm (36")	1226 mm (48.25")	1175 mm (46.25")
1067 mm (42")	1378 mm (54.25")	1327 mm (52.25")
1219 mm (48")	1530 mm (60.25")	1480 mm (58.25")
1372 mm (54")	1683 mm (66.25")	1632 mm (64.25")
1524 mm (60")	1835 mm (72.25")	1784 mm (70.25")
1676 mm (66")	1988 mm (78.25")	1937 mm (76.25")
1829 mm (72")	2140 mm (84.25")	2089 mm (82.25")

**Note:** Unit shown as shortest length available.

# Enclosed Unit

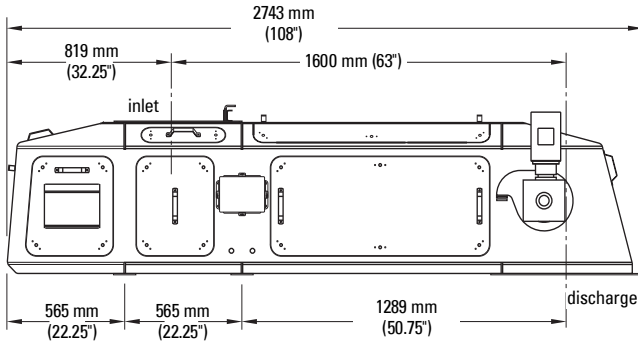
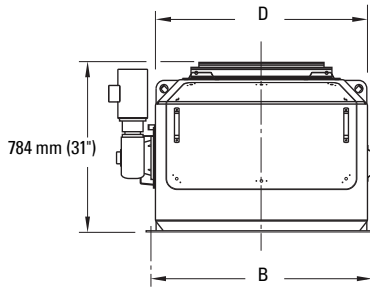

Belt Width	B	D
457 mm (18")	768 mm (30.25")	718 mm (28.25")
610 mm (24")	921 mm (36.25")	870 mm (34.25")
762 mm (30")	1073 mm (42.25")	1022 mm (40.25")
914 mm (36")	1226 mm (48.25")	1175 mm (46.25")
1067 mm (42")	1378 mm (54.25")	1327 mm (52.25")
1219 mm (48")	1530 mm (60.25")	1480 mm (58.25")
1372 mm (54")	1683 mm (66.25")	1632 mm (64.25")
1524 mm (60")	1835 mm (72.25")	1784 mm (70.25")
1676 mm (66")	1988 mm (78.25")	1937 mm (76.25")
1829 mm (72")	2140 mm (84.25")	2089 mm (82.25")

**Note:** Unit shown as shortest length available.



## For more information

[www.siemens.com/level](http://www.siemens.com/level)

[www.siemens.com/continuous-weighing](http://www.siemens.com/continuous-weighing)

Siemens Milltronics Process Instruments Inc.  
Industry Automation (IA)  
1954 Technology Drive  
P.O. Box 4225  
Peterborough, ON  
Canada K9J 7B1

email: [techpubs.smpi@siemens.com](mailto:techpubs.smpi@siemens.com)

[www.siemens.com/processautomation](http://www.siemens.com/processautomation)

Subject to change without prior notice  
7ML19985MQ01 Rev. 2.1

© Siemens Milltronics Process Instruments Inc. 2010



7 M L 1 9 9 8 5 M Q 0 1  
Printed in Canada